



## No. 407-F 37° FLARING TOOL

### OPERATION and SERVICE INSTRUCTIONS WITH REPLACEMENT PARTS LIST

#### I. DESCRIPTION

1-1. This tool is designed to square, deburr and produce 37° flares, conforming to Military Specification MS-33584, in 1/8" hard stainless steel tubing (MIL-T-6845) and other types of tubing.

1-2. This tool will flare 1/8" hard stainless steel tubing in the following sizes and wall thickness:

Outside Diameter In Inches	Wall Thickness In Inches
1/8	.020, .028
3/16	.010, .028
1/4	.016, .028, .035
5/16	.035
3/8	.028, .035
1/2	.035, .049
5/8	.035, .049
3/4	.028, .035, .049
1	.028, .035
1-1/4	.035, .049
1-1/2	.035, .049, .065

1-3. In some cases the wall thicknesses listed above can be exceeded when flaring aluminum, copper or soft steel tubing. The range of wall thicknesses which can be flared in tubing other than stainless steel is best determined by experience.

#### II. METHOD OF OPERATION

2-1. CUTTING TUBING. Cut tubing squarely, using a sawing vise when cutting stainless steel tubing, (Imperial No. 384-FA is recommended) and a fine tooth hacksaw (32 teeth per inch). An abrasive cut-off wheel can also be used for this purpose. A tube cutter should not be used for cutting stainless steel tubing when tubing is to be flared. The tube cutter work hardens the end of the tubing and may cause finished flares to split. When cutting copper, aluminum or steel tubing, a tube cutter such as Imperial No. 274-F or 206-F, may be used.

#### SPECIAL NOTE

Where precision work is required, it is recommended that the squaring and deburring attachments be used with this tool. These attachments are included with this tool.

2-2. MOUNTING AND ASSEMBLING TOOL. Clamp base of tool in a standard machinist's vise. Slots in both sides of base of tool provide gripping surfaces for vise jaws. (See figure 2-1.)

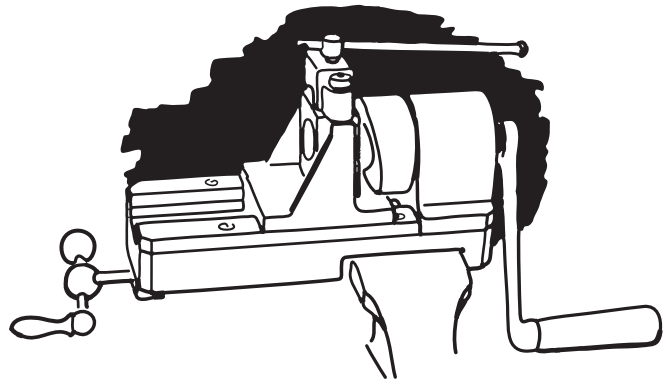

Figure 2-1

a. Assemble operating handle to spindle and tighten retaining thumb screw.

b. Tool is packed with flaring assembly in spindle. In order to remove the flaring assembly, before proceeding with the following steps of operation, back off the carriage screw, grasp the flaring assembly firmly with the left hand and turn spindle operating handle counter-clockwise with the right hand. (See figure 2-2.) Continue turning operating handle until flaring assembly can be removed from spindle opening.

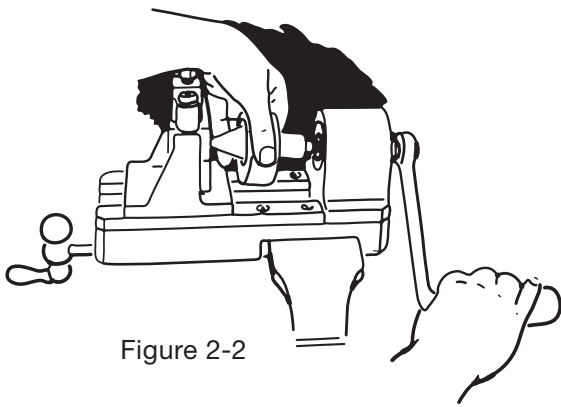

Figure 2-2

2-3. LUBRICATION OF TOOL. Before setting tool into operation, the following points should be lubricated with MIL-L-2104A oil, or any standard lubricating oil, SAE 30 viscosity:

- a. Lead screw, 24, figure 3-1.
- b. Thrust collar, 23, figure 3-1.
- c. Base slide surfaces, 17, figure 3-1.
- d. Clamp screw, 2, figure 3-1.

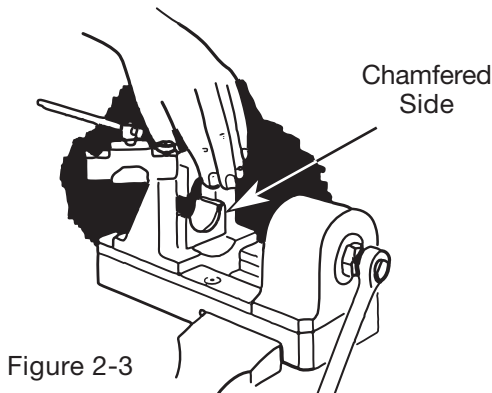

Figure 2-3

2-4. CLAMPING TUBING IN JAWS. Back off clamping screw completely and swing clamp into open position.

a. Place two halves of jaws corresponding to size of tubing to be used in clamping slide with chamfered side of jaws facing spindle. (See 2-3.) Swing clamp into closed position.

b. Insert tubing into jaws so that end of tubing extends toward spindle approximately 1/2 inch beyond face of jaws. Tighten clamp. Back off carriage screw.

2-5. SQUARING TUBING. Insert squaring tool into spindle opening. (See figure 2-4.) The pin on the shaft end of the tool slips into hole at bottom of spindle opening to prevent tool from turning.

a. Advance tubing into squaring tool slowly, by advancing carriage screw, at the same time turning spindle operating handle clockwise. (See figure 2-5.) Continue this operation until face of tubing is completely squared. Do not attempt to remove more material than is necessary.

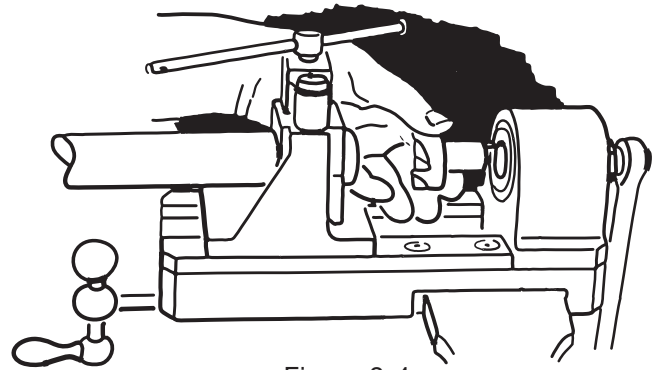

Figure 2-4

b. Retract carriage and remove squaring tool from spindle.

2-6. DEBURRING, INTERNAL. Select proper internal deburring tool for size of tubing being used. The smaller tool is used for 1/8 to 1/2" O.D. tubing.

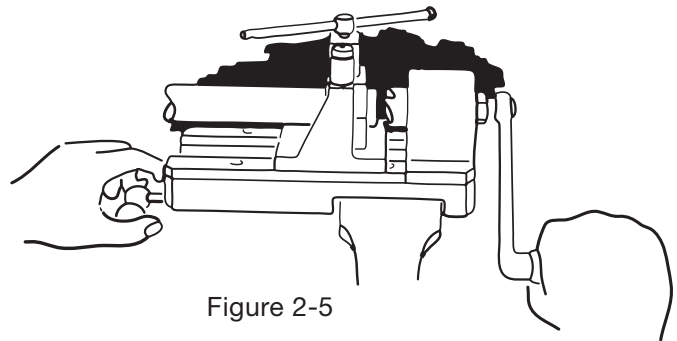

Figure 2-5

The larger tool is used for 5/8 to 1-1/2" O.D. tubing.

a. Place internal deburring tool in spindle opening, engaging pin with hole in spindle. (See figure 2-6.)

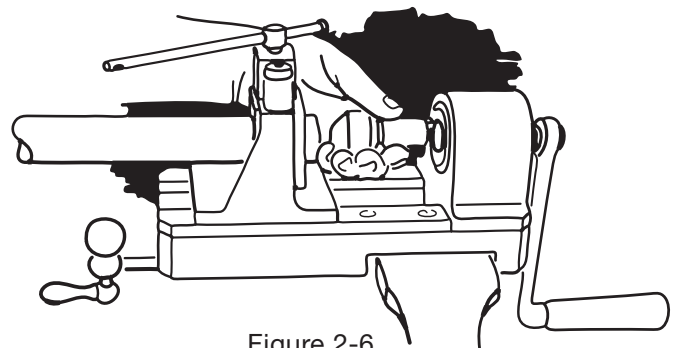

Figure 2-6

b. The tool is spring loaded to prevent over-feeding. Advance carriage until tubing strikes face of cutter. Then advance an additional one revolution of carriage screw. This sets up the automatic pressure feed. Turn spindle operating handle four to five revolutions, without advancing carriage.

c. Retract carriage completely and remove internal deburring tool.

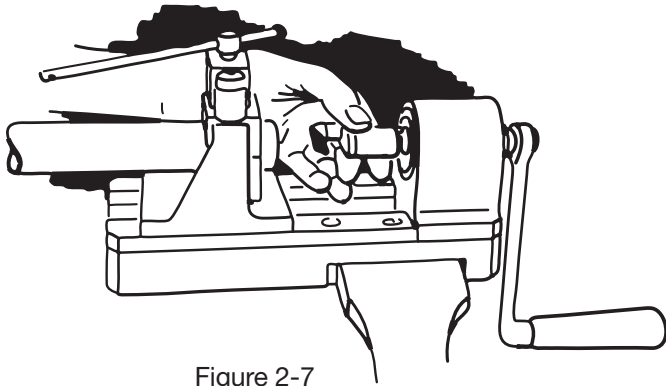

Figure 2-7

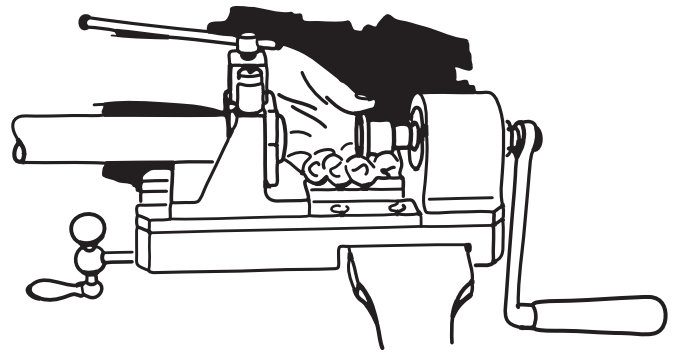

Figure 2-9

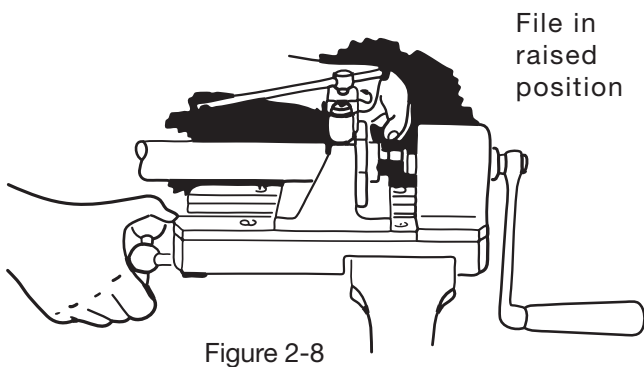

Figure 2-8

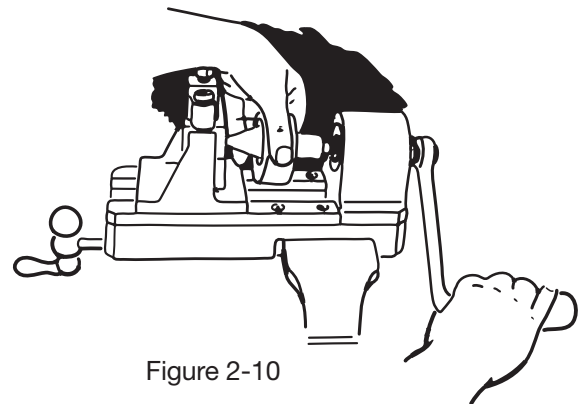

Figure 2-10

**2-7. DEBURRING, EXTERNAL.** Place external deburring tool in spindle, engaging pin with hole in spindle. (See Figure 2-7.)

a. Raise spring loaded file segment, and while holding in this position advance carriage until end of tubing is approximately in center of file. (See figure 2-8.) Release file segment and turn spindle operating handle until complete deburring is accomplished.

b. Retract carriage completely and remove external deburring tool.

**2-8. POSITIONING TUBING.**

a. Back off clamping screw completely and swing clamp into open position. Remove tubing and jaws.

b. All chips, filings and foreign matter should be removed from jaw holder slide, jaws and end of tubing to be flared. Use brush for this purpose.

c. Replace jaws, insert tubing so that end extends approximately 1/4 inch beyond face of jaws. Swing clamp screw into closed position, but do not tighten.

d. The two tube stop gages are marked on the shank with appropriate sizes and wall thicknesses of tubing. Select the proper gage and insert in spindle opening. (See figure 2-9.)

e. Advance carriage until face of tube stop gage contacts face of jaws. This operation has pushed

tubing back to proper depth for flaring. Clamp tubing securely in this position.

f. Retract carriage completely and remove tube stop gage.

**2-9. FLARING TUBING.**

a. Insert flaring tool assembly into spindle. (See figure 2-10.) It will be noted that the shaft of this tool is threaded. Chips and foreign matter should be removed from threads and flaring cone surface. Engage with threads in spindle opening and hand tighten.

b. Advance carriage while turning spindle operating handle clockwise. After tubing strikes flaring cone, continue advancing carriage slowly. Tubing should not be forced into the revolving flaring cone. For best results, turn carriage feed screw approximately 1/4 turn for each revolution of the spindle operating handle.

c. A definite resistance is encountered upon completion of flare. At this point the flare will be pressed against the jaw chamfer.

d. Retract carriage, while revolving spindle operating handle, until the cone is clear of flared surface of tubing. This will insure a flawless and concentric flare.

e. Back off clamping screw and swing clamp into open position. Remove tubing.

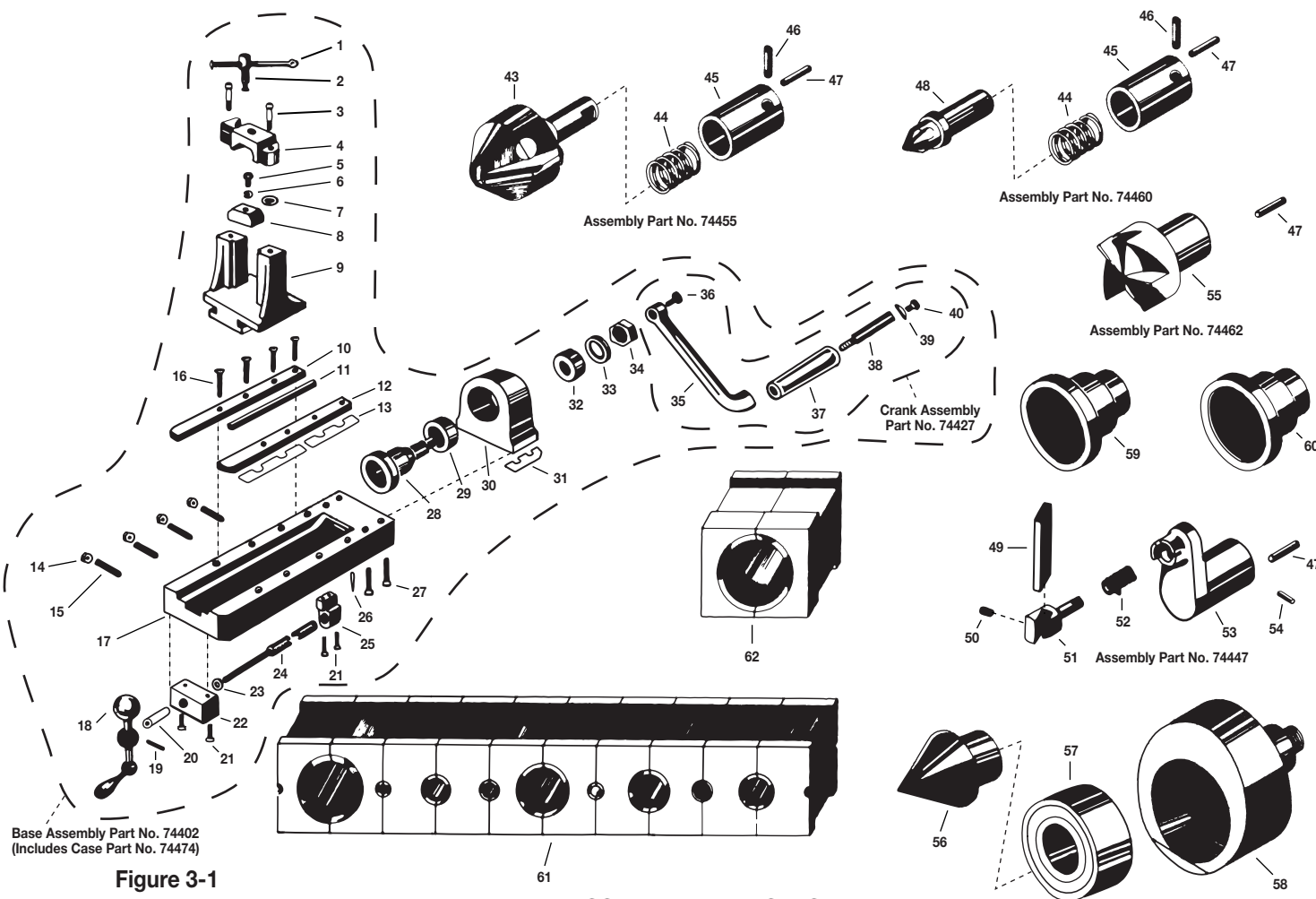

Figure 3-1

ASSEMBLY PARTS LIST

Fig. and Index No.	Part Number	Part Description	Fig. and Index No.	Part Number	Part Description	Fig. and Index No.	Part Number	Part Description
3-1-1	74443	Handle	-23	74438	Thrust Collar	-46	74459	Screw Pin
-2	74442	Clamp Screw	-24	74434	Lead Screw	-47	74453	Coiled Spring Pin
-3	74414	Socket Shoulder Screw	-25	87430-1	Screw Block	-48	74461	Internal Deburring Tool
-4	87431-1	Yoke	-26	74416	Taper Pin	-49	74449	File
-5	74445	Retaining Sleeve	-27	74415	Socket Cap Screw	-50	74450	Socket Set Screw
-6	74446	Retaining Washer	-28	74422	Spindle	-51	74454	Pivot Shaft
-7	74409	Washer	-29	74423	Roller Bearing (1-1/4 I.D.)	-52	74451	Torsion Spring
-8	74444	Pressure Plate	-30	87500-1	Headstock	-53	74448	Holder
-9	87501-1	Jaw Holder	-31	74417	Shim (Headstock)	-54	74452	Coiled Spring Pin
-10	74405	Plate	-32	74424	Roller Bearing (3/4 I. D.)	-55	74463	Facing Tool
-11	74406	Gib	-33	74425	Washer	-56	74466	Cone
-12	74419	Plate	-34	74426	Lock Nut	-57	74467	Ball Bearing
-13	74418	Shim (Tailstock)	-35	74428	Crank	-58	74465	Cone Holder
-14	74411	Jam Nut	-36	74408	Thumb Screw	-59	74470	Tube Stop Gage (.025)
-15	74410	Socket Set Screw	-37	78771-1	Handle	-60	74471	Tube Stop Gage (.040)
-16	74413	Flat Head Socket Cap Screw	-38	74429	Stem	-61	74469	Jaw Set (1/8 - 1-1/4 O.D.)
-17	87502-1	Base	-39	74431	Washer	-62	74468	Jaw Set (1-1/2 O.D.)
-18	74435	Handle	-40	74432	Oval Head Screw		74476	Brush
-19	74436	Coiled Spring Pin	-43	74456	Internal Deburring Tool		74474	Carrying Case
-20	74437	Sleeve	-44	74458	Compression Spring		74422	Flaring Gauge
-21	74412	Socket Cap Screw	-45	74457	Shell			
-22	74439	Thrust Block						

Flaring Assembly Part No. 74464